

SpaceOps-2025, ID #68

The Role of Cloud Computing in Agile Satellite Communication Networks

Alan Campbell^a, Rus Healy^b

^a*Principal Space Specialist Solutions Architect, Amazon Web Services, alanwc@amazon.com*

^b*Senior Solutions Architect, Amazon Web Services, rushealy@amazon.com*

Abstract

The ground is changing for satellite communication (Satcom) systems. Operators are seeking to move towards digital teleports to reduce physical infrastructure, enable seamless modem upgrades, and avoid vendor lock.

The new Waveform Architecture for Virtualized Ecosystems (WAVE) Consortium aims to transform the Satcom industry to a fully interoperable ecosystem using intelligent, open, and virtualized networks with standardized architectures.

This track discusses the role of Cloud Computing in this new path forward. Vendors can publish optimized waveforms in the Cloud marketplace for operators to consume. Government workloads can leverage multiple vendors, yet still achieve a common heterogeneous computing hardware platform, switching seamlessly between waveforms.

Scalability and cost-efficiency are achieved via selection of the appropriate compute instance type. For example, General Purpose Processors (GPP) may be suitable for demodulating and decoding smaller amounts of satellite bandwidth, while Field-Programmable Gate Arrays (FPGAs) can maximize digital Intermediate Frequency (IF) modem density in higher-bandwidth scenarios.

Finally, regional versus edge tradeoffs are discussed. The flexibility of on-demand compute in-region is key. However, some use cases require low latency, and thus the same Cloud compute instance types need to exist at the edge (teleport).

Keywords: satellite communications, Cloud computing, WAVE Consortium, virtualization, scalability, edge computing

1. Introduction

Traditional satcom ground infrastructure, characterized by proprietary hardware and vendor-specific solutions, is giving way to more flexible, scalable, and interoperable systems. This shift is driven by the need for greater agility in response to market demands, simplified upgrade paths, and reduced operational costs.

The formation of the Waveform Architecture for Virtualized Ecosystems (WAVE) consortium in March 2024 marks a significant milestone in this transformation. WAVE aims to create a standardized, open architecture that enables the virtualization of satcom waveforms, fostering innovation and interoperability across the industry.[1,2]

Cloud computing plays a pivotal role in enabling this new paradigm. Vendors can publish differentiated waveforms to a Cloud marketplace opening doors to broader markets. Operators can decide which packages to

integrate based on cost, efficiency, or sovereignty tradeoffs thus enhancing Satcom solution network scalability, and avoiding vendor-lock.

General purpose processors (GPP) and accelerated compute instances are equally important in Software Defined Radio (SDR) architectures for agile satcom. New generations of Cloud-based GPP instances are frequently introduced enabling customers to upgrade and benefit from more cost-effective waveform processing with very little effort. FPGA-accelerated instance types enable larger amounts of satellite bandwidth to be efficiently processed, since they are an order of magnitude more computationally efficient than GPPs on specific functions within the waveform, such as error correction.

This paper explores the pivotal role of cloud computing in enabling this new paradigm for satellite communications. We will discuss how cloud platforms are facilitating the transition to digital teleport infrastructure, offering new business models, and addressing key challenges in scalability, flexibility, and cost-efficiency.

1.1 Satcom industry ground architecture

Large Satcom hubs are typically comprised of hundreds of fixed hardware modulators, demodulators, combiners, splitters and filters, as shown in Fig. 1. Radio signals are transmitted to the remote terminal through the satellite (forward link) and received from the terminal through the satellite (return link) at the hub ground station's antenna system. The received high-frequency signal is then passed through a downconverter, which reduces the frequency of the signal to a lower intermediate frequency. The result is a lower frequency IF signal that is easier to process. Finally, the signal is demodulated to extract the original data, which is then sent to the appropriate network components.

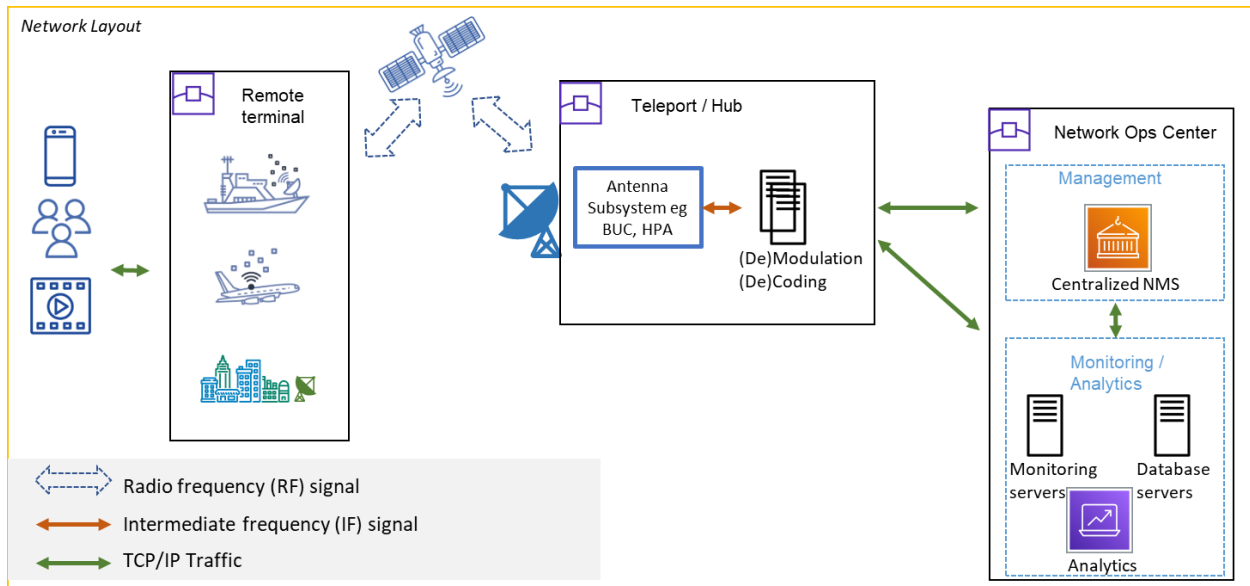

Fig. 1: Architectural diagram of a traditional satellite communications system

Provisioning new customer missions is a manual process of installing ground segment components. Peak holiday air travel or major sporting events can more than double the satellite bandwidth demand, but satellite operators have limited ability to scale up, and also down when peak events end. Proprietary hardware systems can rarely be repurposed for new missions. Furthermore, if hardware components of the ground segment fail, like a satcom modem, for example, it often requires a human interaction, which increases service restoration time.[3]

1.2 Software-defined satellite ground systems

In 2020, the US DoD's Fighting Satcom Vision outlined the need for agile terminals and flexible ground segments. The WAVE Consortium is included in the Senate Armed Services Committee's 2025 National Defense Authorization Act (NDAA), recognizing the crucial role in advancing waveform virtualization standards for satellite communications.[4,5]

Kratos Defense & Security Solutions, Inc, a technology company in the defense, national security and global markets, offers the OpenSpace® family of solutions that enable the digital transformation of ground systems. The ability to introduce new revenue streams is evidenced by the partnership with Radisys® Corporation to build a cloud native end-to-end 5G solution for non-terrestrial networks leveraging the OpenSpace Platform.[6]

Clearly, the ground segment is changing to more flexible, scalable software-defined systems. The remainder of this paper will focus on the role of Cloud computing in agile satcom networks, highlighting the benefits and challenges, and exploring tradeoffs between processing waveforms at the Cloud Region versus the Edge (hub). There is room for both GPP-only and FPGA-based approaches to the problem, however the fundamental architecture using SDRs remains the same.

2. Cloud-Enabled Digital Teleport Infrastructure

In a Cloud-based satcom hub, the L-band IF components are replaced by a digitizer, software channelizer and combiner, and one or more SDRs processing waveforms, as shown in Fig. 2.

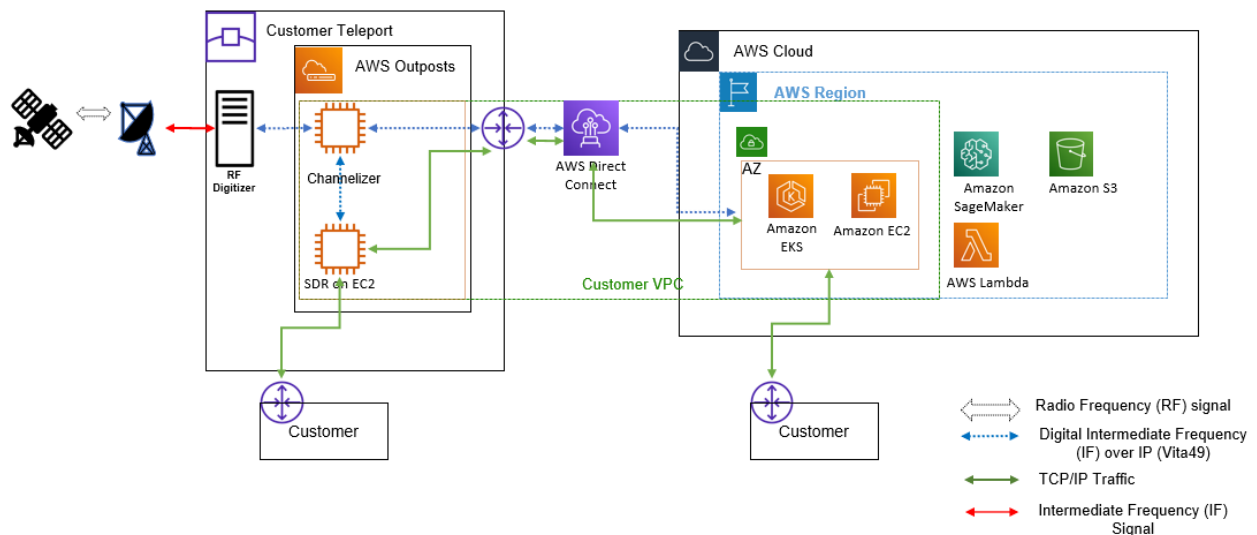

Fig. 2: Architectural diagram of a virtualized satcom system with SDR (de)modulation, (de)coding in AWS Cloud

Region-based processing is a good choice for event or disaster management use-cases. Operators can spin up and tear down compute based on bandwidth demand.

For optimal performance, AWS Outposts can be deployed at the teleport as an extension of an AWS Region. This architecture places the channelizer and SDR as close as possible, from a networking standpoint, to the RF digitizer, minimizing latency.

A dedicated network connection, such as AWS Direct Connect, is recommended between the teleport and AWS, bypassing the public internet, for private, consistent, and reliable connectivity.

Historically, the lack of satcom-optimized compute instances has presented a challenge to delivering efficient Cloud-based solutions. The current F2 FPGA instances are well-suited to the category of virtualized satcom applications. Based on the AMD Virtex UltraScale+ VU47P FPGA, satellite operators can (de)modulate and (de)code multiple waveforms in the cloud.

2.1 Orchestration of satcom waveforms

Agile multi-waveform capabilities enable rapid reconfiguration in the field, which is advantageous for scenarios such as military personnel switching to a new protocol to make communications more secure. Orchestrating the clearing and loading of different waveforms becomes a critical requirement for the new, flexible ground segment. This flexibility is also useful between migrations from one generation of wireless technologies to the next, without the need for significant equipment replacement.

GPP-based satcom solutions can take advantage of standard container orchestration services such as Kubernetes to deploy, manage and scale applications. Amazon Elastic Kubernetes Service (Amazon EKS) is a popular, fully-managed service, providing a highly available and secure Kubernetes control plane.

FPGA-based systems typically provide management tools to load and clear waveforms. An example is shown in Fig. 3 for the F2 instance type. Each supplier builds their design check point (DCP) using their chosen tooling. An Amazon FPGA image (AFI) would typically be built for each waveform with its own differentiated algorithm, then deployed into AWS Marketplace. The Operator then ingests AFI programmatically using the APIs available in the F2 development kit.

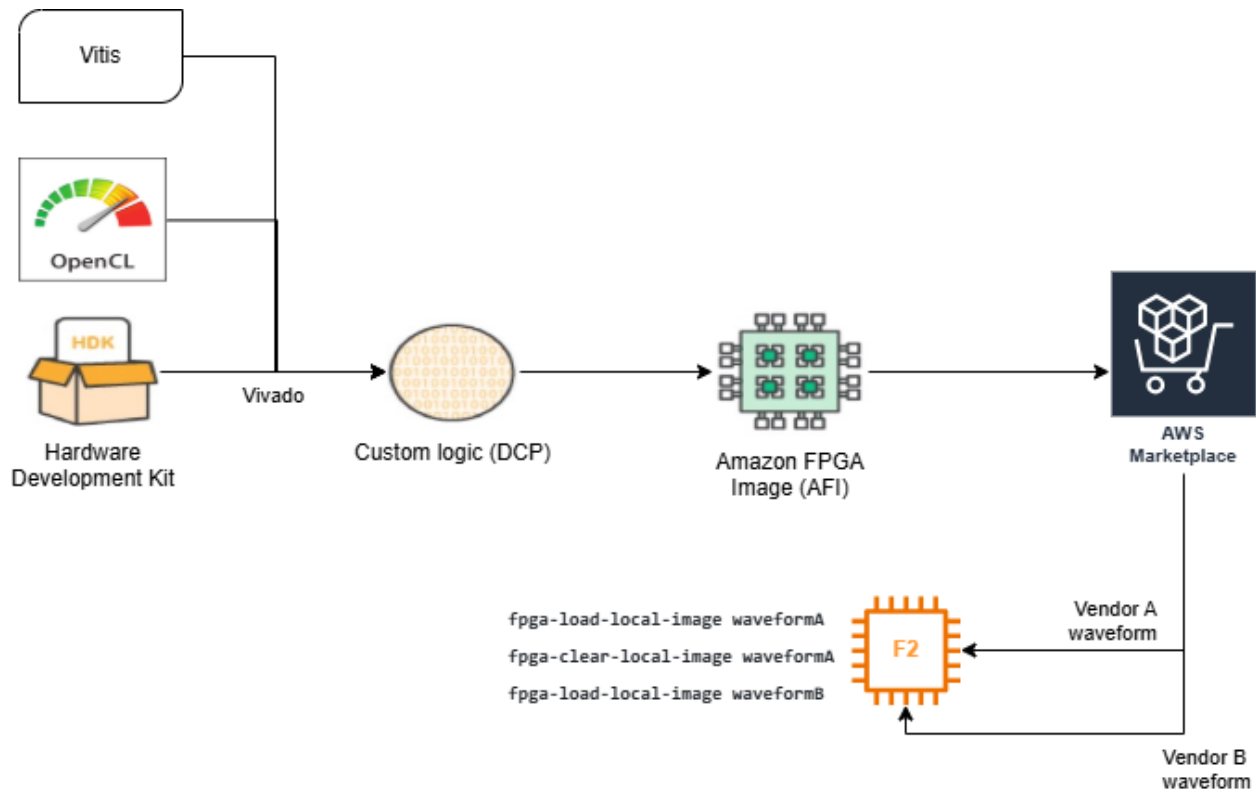

Fig. 3: Waveform orchestration with EC2 F2 FPGA

2.2 Networking requirements

Agile satcom imposes substantial networking requirements. Demodulating a satcom RF waveform and transforming it into digitized intermediate frequency (DigIF) streams produces approximately a 1:20 expansion in data rate. That is, 100 MHz of RF bandwidth equates to 2 Gbps of DigIF data, assuming an 8-bit sample rate.

It is important to select a Cloud compute instance type with sufficient network bandwidth. A [c7i.4xlarge](#), at 12.5 Gbps, could process approximately 500 MHz of RF with some margin, whilst an [f2.48xlarge](#) (eight FPGAs, 100 Gbps) could accommodate approximately 4 GHz, split across eight or more channels.

3. New opportunities with digital ground infrastructure

Baseband processing in the IP domain gives rise to a new set of opportunities to improve efficiency or monetize novel solutions.

Beamforming, a complex signal processing task using antenna arrays to improve data rates, can take advantage of vast cloud computing power. Interference mitigation can be applied to minimize the impact of rogue carriers as they are detected. Signal identification, user geolocation, and backscatter radar are all potential areas for new applications leveraging cloud-based solutions.

[Integrasys](#), specializing in satellite network design and monitoring tools, offers a virtualized ground system for testing DigIF modems and hubs. It also monitors in real-time teleports and multi-orbit satellite networks with VirSat and Controlsat.

Artificial Intelligence and Machine Learning (AI/ML) can be applied to gain new data insights. An [example](#) is detecting digital RF signal impairments using IQ Constellation plots, as shown in Fig. 4. Firstly, clustering is applied to detect the modulation type, then ML classification is performed on a trained model against various RF impairment categories. The model infers this example to be phase noise, since the points are smeared arc-like around the origin.

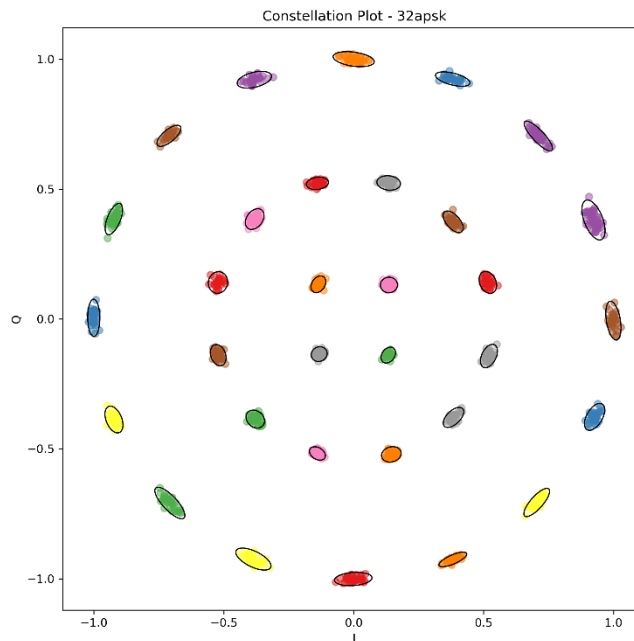

Fig. 4: Phase noise impairment of a 32APSK constellation

4. Conclusions

The shift to digital teleports in the satellite communications industry is beneficial for both modem vendors and operators.

Vendors can publish optimized waveforms to a Cloud marketplace providing a global distribution channel. Operators can deliver more agile networks scaling up for new missions, reducing operational overheads, and avoiding vendor-lock.

Cloud computing is a key element in the equation. Upgrading to new instance types offers a simple way to deliver more bandwidth, while Outpost-based teleport deployments provide low-latency solutions with the same tools for orchestration and security as the cloud region.

Finally, new revenue streams leveraging AI/ML Cloud tooling can be realized with customer demand for advanced beamforming and interference mitigation presented as initial examples.

References

- [1] J. Deaton, "High Stakes in High Ground: Can Innovation and Defense Investment Help GEO Compete with LEO?" Via Satellite, March 2025.
- [2] R. Jewett, "WAVE Consortium Debuts to Promote Virtualized Ecosystems," Satellite Today, March 18, 2024.
- [3] C. Reglero, N. Ansell, E. Salcedo, J. Arora, "Virtualizing satellite communication operations with AWS", September 6, 2022
- [4] "WAVE Consortium Recognized in Senate Armed Services Committee's 2025 National Defense Authorization Act," WAVE Consortium news release, August 13, 2024.
- [5] M. Holmes, "Ground Tech CEOs Talk Digitization, Standards and Antenna Progress," Via Satellite Show Daily, March 2025.
- [6] "Kratos and Radisys Partner on Cloud-Native 5G NTN OpenSpace Solutions to Enable Seamless Satellite Access for Terrestrial Networks," Kratos Defense news release, March 2024.