

**ISIS Product Line: a solution for a  
small constellation Ground Control Center**

**Angéla Mithra<sup>a\*</sup>, Sara Manglaviti<sup>b</sup>, Olivier Churlaud<sup>c</sup>**

<sup>a</sup> CNES Toulouse, France, [angela.mithra@cnes.fr](mailto:angela.mithra@cnes.fr)

<sup>b</sup> CNES Toulouse, France, [sara.manglaviti@cnes.fr](mailto:sara.manglaviti@cnes.fr)

<sup>c</sup> CNES Toulouse, France, [olivier.churlaud@cnes.fr](mailto:olivier.churlaud@cnes.fr)

\* Corresponding Author

**Abstract**

Satellite constellation projects are becoming an increasingly important part of the space industry market in the last few years. The reduction in launch costs, the choice of using small satellites and the increase in reliability of space technologies are the most important points that make constellations so successful. Small fleets (with around 50 satellites) can provide a continuous coverage of Earth surface and an intersatellite link may virtually enable full time visibility for the fleet. Therefore, Earth observation, Internet of Things (IoT) and telecommunication missions are the most invested clients in these new growing technologies.

Aware of the complexity of the constellation missions, the French Space Agency CNES has decided to adapt its new Command Control Center (CCC), the ISIS Product Line (ISIS-PL), in order to respond to the new system needs. The whole infrastructure has been revised, some subsystems reconsidered and new operational concepts proposed.

ISIS-PL was chosen in 2020 to develop a CCC for a constellation of 25 nanosatellites for Kinéis. Kinéis is a satellite operator that is deploying Europe's first nanosatellite constellation dedicated to IoT. The CCC named Ground Control Segment (GCS) needed to be used continuously in all operational stages with very different specificities:

- LEOP (Launch and Early Orbit Phase) with a rapid and high availability satellite telemetry processing,
- In Orbit Validation which is not clearly defined before satellites launch,
- Satellites fine positioning with a strict planning,
- Routine phase that must be full automatic and robust in order to keep the operators focus on major contingencies.

Moreover, since the constellation is deployed in 5 launches of 5 satellites (successful first launch on June 20<sup>th</sup> 2024), the GCS needed to manage multiple phases at the same time.

The aim of this paper is to present how the ISIS-PL has been adapted for this new purpose, the new operational concepts introduced, the challenges completed and, most of all, all principal choices that make the ISIS-PL CCC a ground control center with a great adaptability to multiple operational changes.

Another important point is that with a constellation mission the operators need to easily monitor the health of the entire constellation. Therefore, synthetic tools are absolutely necessary. The paper presents how to understand the new needs of the operators and describes the conception of the synthetic views. The challenge here is to gather information in an ergonomic view and to build a tool that can be reused.

**Keywords:** Constellations, Command Control Center, ISIS-PL, Kinéis

**Acronyms/Abbreviations**

Automatic Identification System (AIS)

Assembly Integration Validation (AIV)

Center National d'Etudes Spatiales – The French space agency (CNES)

Command Control Center (CCC)

CONcepts Of OperationS (CONOPS)

Control Operation File (COF)

Command Operation Protocol 1 (COP1)

Flight Control Procedures (FCP)

Flight Dynamics System (FDS)

Ground Control Procedures (GCP)

Group Of Operations (GOO)

Ground Segment (GRS)

Human–Computer Interaction (HCI)

Housekeeping Telemetry (HKTm)  
Human Machine Interface (HMI)  
In Orbit Validation (IOV)  
Initiative for Space Innovative Standard (ISIS)  
Internet of Things (IoT)  
ISIS Product Line (ISIS-PL)  
Launch and Early Orbit phase (LEOP)  
Monitoring and Control (M&C)  
Mission Control Segment (MCS)  
Main Control Room (MCR or SCP in French)  
Operational Orbit Center (COO)  
PULP is the Unified Layer Package (PULP)  
Packet Utilisation Standard (PUS)  
System Data Base (SDB)  
Sequence Of Operations (SOO)  
Telecommand (TC)  
Telemetry (TM)  
View for Satellite Status (V2S)  
Virtual Machine (VM)

## 1. Introduction

### 1.1 *Kinéis, a constellation of 25 bi-payload satellites*

Created in 2018, Kinéis is a French IOT satellite operator. It provides connectivity everywhere especially where no other network is available. It is a near-real-time connectivity with a revisit time between 15 minutes and 1 hour in the worst case. To offer this service Kinéis has launched a constellation of 25 satellites with an exceptional rate of 5 launches in 9 months. The nanosatellites weigh 28 kilograms and will orbit the earth at an altitude of 650 kilometres for 8 years.

Two missions are supported by the Kinéis system: Argos and AIS. Argos system is inherited from the wild animals' detection in the world and allow with Doppler effect to locate objects. Payload AIS is dedicated to signal detection of high performance for world sea traffic monitoring.

The constellation is evenly spread along 5 orbital planes. Each orbital plane is covered by 5 satellites that are launched simultaneously, with the following payload characteristics:

- 3 satellites with ARGOS payload only (no AIS)
- 2 satellites with ARGOS and AIS payloads

Depending on orbits and satellite ageing, bi-mission (AIS and ARGOS) might be allowed. In any case (ARGOS or AIS satellite), TC link uses ARGOS payload for satellite commanding. The constellation is a Walker-Star (20, 5, 1) [1] in which prime AIS satellites (in red in Fig. 1) are added to minimize collisions risks, and backup-AIS satellites are their nearest neighbours. This allows to perform both missions on all orbital planes, without interfering with each other. The naming convention is 1 to 5 for planes and A to E for satellites

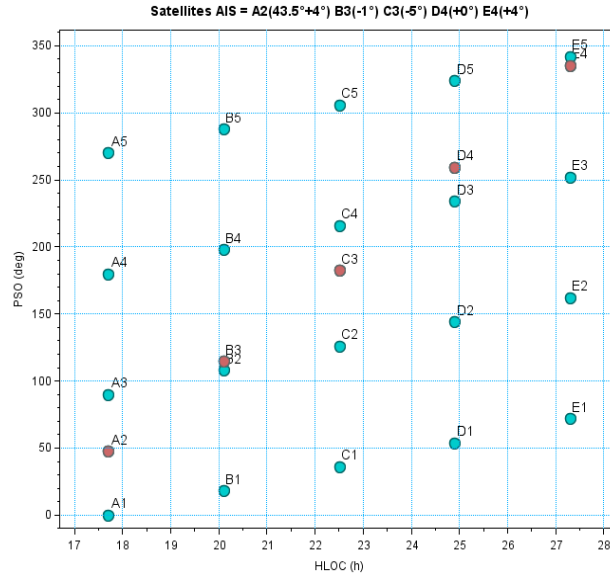

Fig. 1. Kinéis constellation diagram

### 1.2 ISIS-PL a rapid and flexible solution for a small constellation

ISIS stands for Initiative for Space Innovative Standard, a standardization project for CNES satellite missions, of which the ISIS-PL is the command control center (CCC) component implementation. The ISIS-PL is used for all CNES missions and also for this specific mission Kinéis. More information on ISIS-PL are given in [5]. The CCC named Ground Control Segment (GCS) needed to be used continuously in all operational stages with very different specificities:

- LEOP (Launch and Early Orbit Phase) with a rapid and high availability satellite telemetry processing
- In Orbit Validation which is not clearly defined before satellites launch
- Satellites fine positioning with a strict planning
- Routine phase that must be full automatic and robust in order to keep the operators focus on major contingencies

Moreover, since the constellation was deployed in 5 launches of 5 satellites (successful first launch on June 20<sup>th</sup> 2024 and last launch on March 2025), the Ground Control Segment needed to manage multiple at the same time.

The aim of this paper is to present how the ISIS-PL has been adapted for this new purpose, the new operational concepts introduced, the challenges completed and, most of all, all principal choices that make the ISIS-PL CCC a ground control center with a great adaptability to multiple operational changes.

Another important point is that with a constellation mission the operators need to easily monitor the health of the entire constellation. Therefore, synthetic tools are absolutely necessary. The paper presents how to understand the new needs of the operators and describes the conception of the synthetic views. The challenge here is to gather information in an ergonomic view and to build a tool that can be reused.

These topics are covered in the following chapters.

## 2. Kinéis Ground Control Segment

The following figure (Fig. 2) shows how the GCS stands in the whole architecture of the Kinéis system.

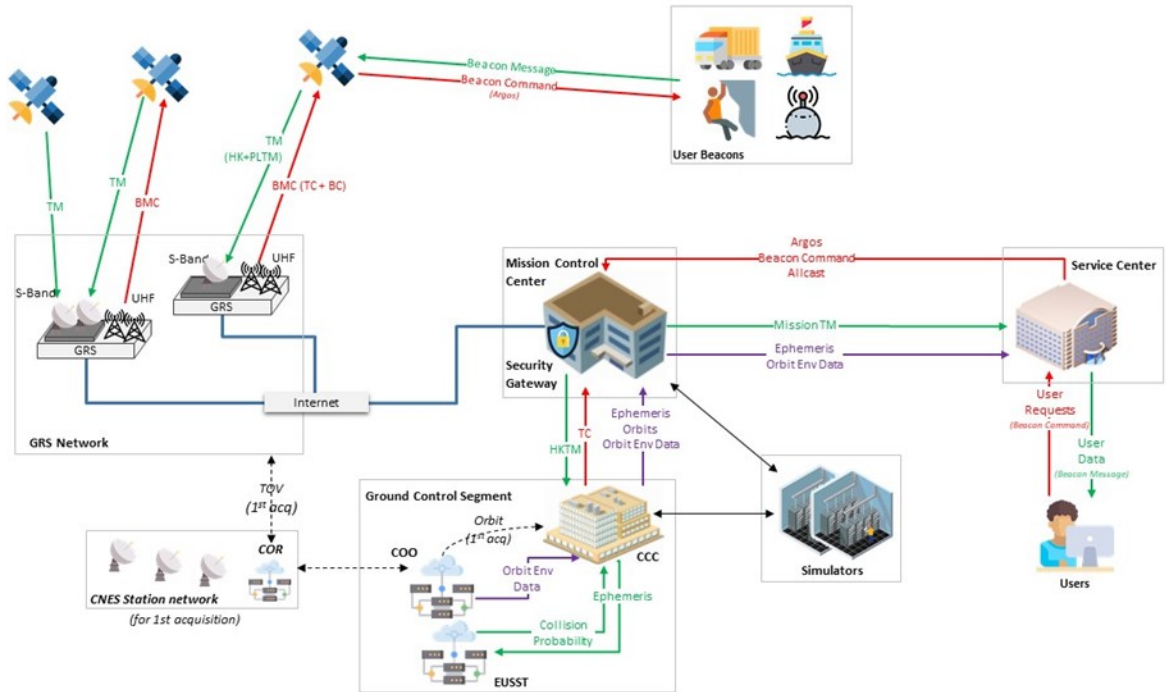

Fig. 2. Kinéis system architecture

Kinéis **Ground Control Segment** is made of:

- A generic CCC, including the flight dynamics component (FDS) based on CNES Product Lines ISIS and SIRIUS respectively,
- An Operational Orbit Center (COO) that provides information on solar activity and earth rotation from international servers
- An European Union Space Surveillance & Tracking (EUSST) centre that analyses and informs the CCC about collision risks.

Unlike most of operational CCCs hosted in CNES premises that include real time telemetry acquisition and monitoring, commands encoding and uploading, tasks performed in Kinéis CCC are “limited” to the following:

#### Management of TM and TC history

- Process HKTMR in differed time including on board alarms processing
- Compute ground monitoring
- Archive the HKTMR and control TC for 30 days,
- Process HKTMP in near real time if needed in some specific phases (no real time reception and decoding),
- Compute on board and ground time delta thanks to HKTMP partial processing
- Manage the satellite control configuration,
- Support control by operations expert via TM analysis, and provide results of this monitoring to operators and a synthesis to the MCS,
- Provide monitoring information on the space segment to MCS.

#### Orbit computation and control

- Compute flight dynamics operations for LEOP (ascent plan), nominal and reconfiguration phases,
- Manage collision avoidance using EUSST services,
- For all phases (LEOP and routine), determine and predict the orbits using Doppler measurements from TM downlink,

- Distribute ephemeris and orbital environmental data to the Kinéis system.

### **Generation of the platform commands**

Generation of immediate or timetagged TC that are provided to the Mission Control Center (MCS) in order to:

- upload orbit parameters,
- upload satellite/ground visibilities plan (switch ON/OFF of telemetry transmitter)
- switch ARGOS ON/OFF for AIS only satellite,
- upload maneuvers (including collision avoidance maneuver),
- provide ground/board time synchronization,
- modify satellite parameters during mission lifetime (for instance, battery loading parameters...),
- manage On-Board software updates,
- perform recovery operations from satellite SAFE Handling Mode,
- switch equipment OFF at end of life

### **Scheduling and Operations**

- schedule all operational activities in the CCC
- raise alerts to the operators in critical cases

Thus, several tasks of a typical command control line are not performed by Kinéis CCC but by the MCS such as:

- Reception from the ground remote stations of payload and platform Telemetry in real time,
- Merge of the payloads TC and platform TC (and beacon commands),
- Reservation of Ground Stations support,
- Management and allocation of the TC uplink plan for each station and each satellite,
- Monitoring and control of the payloads (first level monitoring only is done at CCC level).

Fig. 3 shows a summary diagram of the main functions of the Kinéis system and the way in which exchanges take place at GCS level.

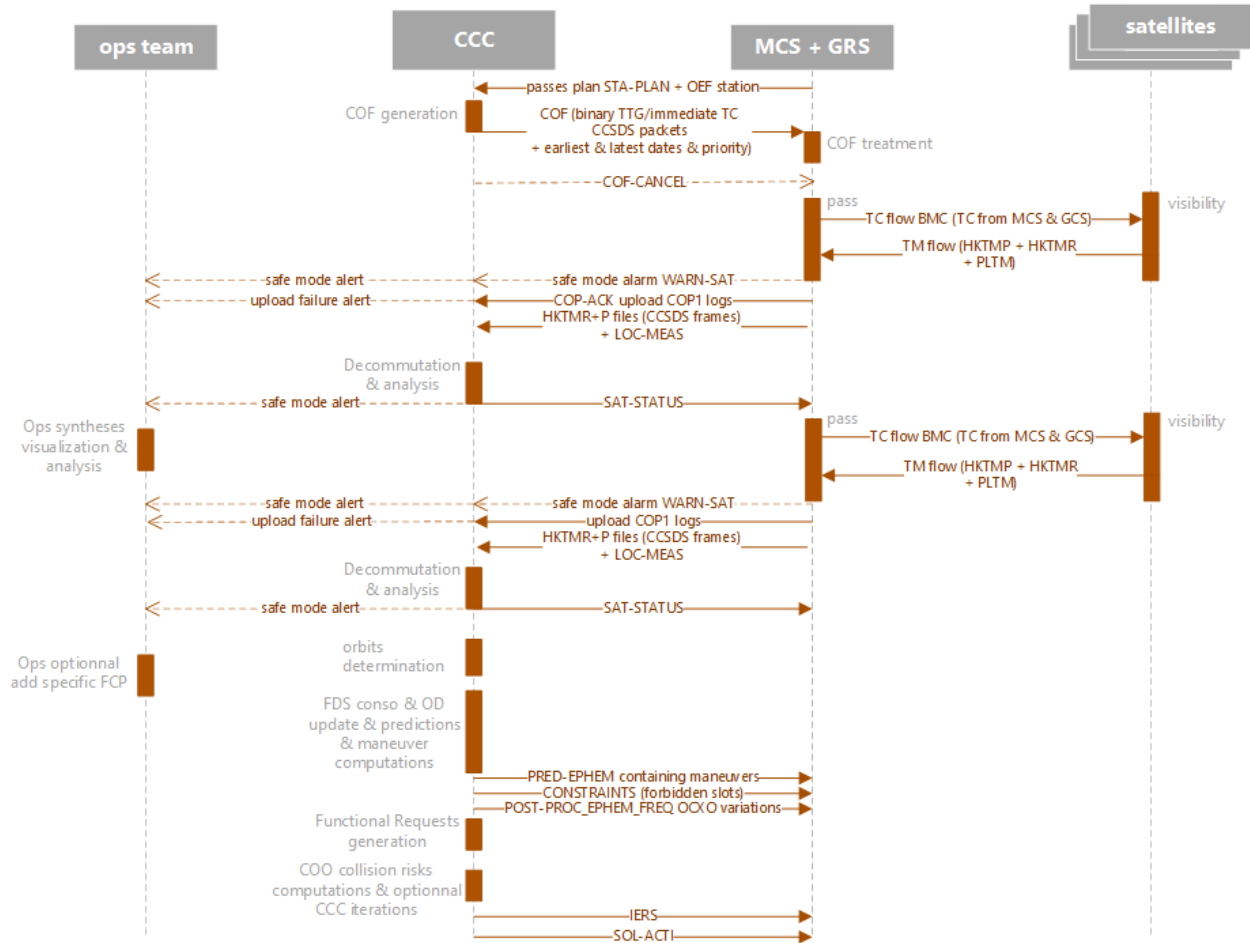

Fig. 3. summary diagram of the main functions of the Kinéis system

For routine operations, the satellite design shall ensure that GCS interventions are limited to support for:

- Maneuvers (including collision avoidance),
- Recovery operations from satellite SAFE mode,
- Upload of orbit parameters,
- Upload of satellite/ground visibilities plan,
- Scheduling ARGOS ON/OFF for AIS only satellite,
- Ground/board time synchronization,
- Modification of satellite parameters during mission lifetime (for instance, battery loading parameters...).

### 3. PULP and MIG context

The CCC for Kinéis mission is based on the ISIS Product Line, which is used by all missions operated by CNES in the frame of the ISIS standard. This Product Line is tailored for each mission, via configuration and/or additional software or tools developments (see Fig. 4).

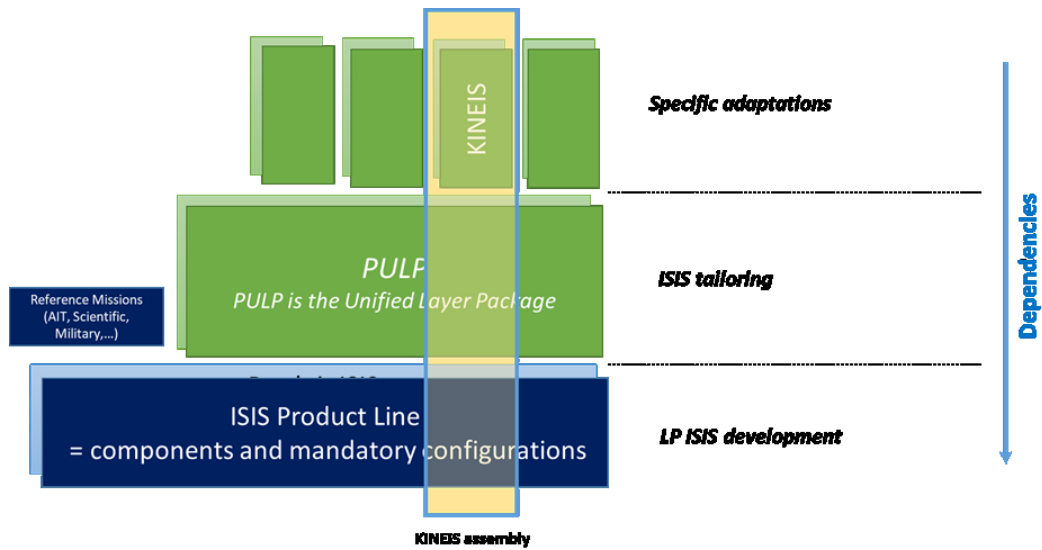

Fig. 4. Overview of software layers for Kinéis mission assembly

Before Kinéis missions, in-flight missions operated thanks to ISIS Product Line have a maximum of three satellites and cover very different type of missions, from a quick-and-cheap nanosatellite mission to an emblematic scientific mission.

In order to optimize the AIV and operational qualification phases of a control center (i.e. to validate the proper functioning of all the components and subsystems of the CCC ISIS product line but also its operational use within the operational system), CNES has defined assemblies.

Thus, a mission can focus on what is specific and inherit an assembly pre-validated, maintained and meeting the generic needs of CNES missions. These shared elements constitute the PULP environment.

PULP therefore responds to a logic of genericity, cost and time reduction, and knowledge capitalization. This missionization base includes:

- Dependencies common to all missions (libraries, tools, etc.),
- Automated deployment means,
- Configurations to apply,
- Campaigns and automated test/data sets to be performed,
- A definition of missionization processes to be followed.

PULP is constantly evolving with the evolution of the CCC ISIS product line and the new needs expressed by current and future missions. PULP is continuously developed by a community of “users” of CCC (Ground Operators, Board Operators or AIV teams), of as-well in-flight missions than in-development missions. A new release of the PULP environment is delivered approximately every 2 months, and its content is agreed by a set of commissions.

In order to ensure the proper functioning of PULP, a “fictitious” validation mission, called MIG, has been defined. It allows to arbitrarily define a validation context allowing to implement the different subsystems in representative scenarios of operations. It is also the guarantee allowing new developments to take place in the lower layers and shared between all the missions (LP CCC ISIS and PULP) while taking maximum care not to introduce regressions in the different missions.

The Kinéis mission is one of the first missions to benefit from these working methods. The Kinéis AIV tests have been derived as much as possible from the MIG tests, while remaining adapted to the mission and the Kinéis data. The tests developed for Kinéis have been as generic as possible so that they can be transferred to MIG and benefit future missions. The stress of the ISIS Product Line, not conceived at its start for constellation, allowed to reveal corner anomalies (mainly on back components or on leak behaviors). Anomaly’s corrections will be for the benefit of future missions too.

## 4. Architecture

### 4.1 Means

In order to manage several phases in parallel (LEOP, routine, contingency, decommissioning operations, troubleshooting/investigations), Kinéis CCC provides several « lines », that are deployed on the ISIS Product line basis, and configured and customized for Kinéis specific needs:

- “Production” that is the nominal operational line,
- “Expert” that is available during LEOP operations, it is a “virtual” Main Control Room for the experts’ work (also called SCP)
- “Essai” that is similar to Production line and used for Integration/validation process
- “Essaicc” (command/control) that is dedicated to operators to validate their Flight Control Procedures and perform simulations in case of contingencies.

There is no physical MCR room in the Kinéis system; all operators/experts will share the same room during LEOP, although the configuration for experts gives limited access to servers and data. Once the “Experts” line is not needed anymore, means may be spread over the remaining lines.

The backup CCC, used as a cold redundancy of the prime one, is equipped with limited means (fewer lines).

#### *4.2 Production line*

A detailed description of the “Production” line is given in Fig 5. It includes the following VMs:

- installer: deployment and administration server
- master, scheduler: control center orchestrators
- supervision: infrastructure and software supervision of all computers in the CCC
- interface: SFTP client, interfaces conversions
- mcstore, eventstore: time-based data storage (events, telemetry, ...)
- dataserver: time-based data requests handling
- fileserver: Ground Control Procedures, Flight Control Procedures, configurations storage
- desktopx: operators’ HMI including FDS HMI and workspace (x 8)
- mcworker: TM/TC processing (PUS, alarms...) (x 6)
- FDS Server: Flight dynamics computations (x 5), one server for each plane, containing and computing orbital information for five satellites allocated in the same plane
- mcmaster: HKTMR (Recorded Housekeeping TeleMetry) processing
- mission: Mission specific process
- server SFTP: interfaces’ file exchange with COO entity
- Statistical Analysis Tool: Data Archive for Investigation and Synthesis/reports

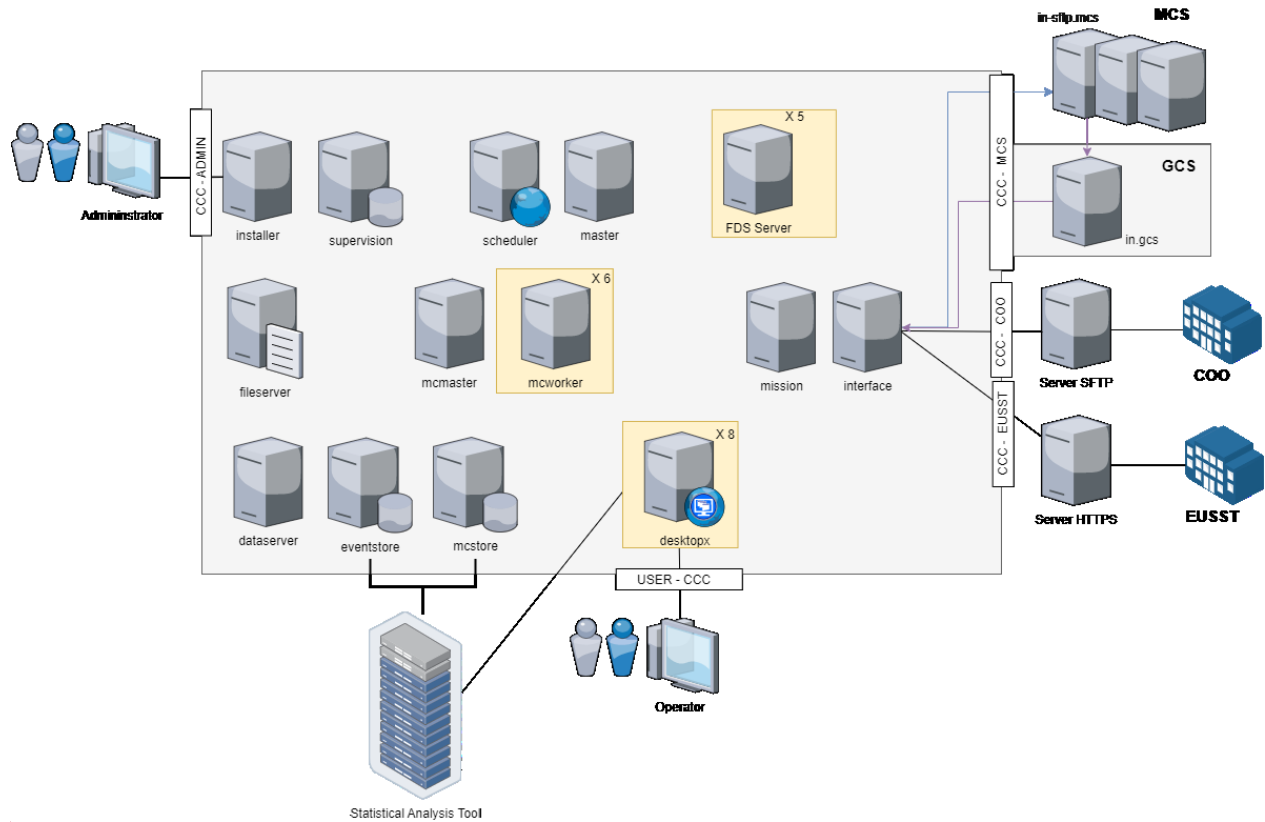

[MA1]

Fig. 5. Production line description

The various CCC-ISIS functions, and therefore hardware resources, have not been multiplied by 25: each VM is unique and is used by all the 25 satellites, with the exception of VMs that cannot host all 25 functions in parallel, such as mcworker or FDS, which only host 5 satellites at a time. Each desktopx allows two users to work in parallel. The number of desktopx was sized according to the phases (increased at peak operations and decreased when the routine was in place).

#### 4.3 Configuration and flexibility

The proposed architecture is in line with the current system needs: a final constellation of 25 satellites equally spread on 5 different orbital planes. Thus, the configuration shall take into account, with no impact on the design of the CCC:

- a flexible number of operational satellites (1 to 25) all along the constellation building phase;
- a flexible number of operational satellites on a given orbital plane (1 to 5).

On the overall, the CCC is fully configurable at several levels:

- means (workers, servers) instantiation and configuration,
- software deployment and configuration,
- satellite and system Data base management,
- procedures management,
- etc.

To extend the constellation or modify satellites distribution, modifications may be needed, such as the addition of VMs or other means, review of the number of mcworkers or FDS instances for instance. Besides, adding more satellites or means may imply, among other topics, to:

- Check on the ability to handle software configuration and implementation of activities common to all satellites,
- Assess time performances.

## 5. Monitoring and Control

### 5.1 TM, HKTM files

The house-keeping telemetry is received by MCS from the ground stations using the S-BAND, and then sent to the CCC. There are two kinds of house-keeping telemetry:

- HKTM-R: Recorded HKTM is stored on-board, downloaded on request, and made available shortly (approximately 10mn) after the visibility pass used for download,
- HKTM-P: Processing TM usually generated in real-time and downlinked whenever TM link is available, is sent by MCS to the CCC in near-real time, every minute

Once the HKTM file is received by the CCC, an acquisition process will be launched in order to read the file and to store the raw telemetry data in the time-based data. The same acquisition process is launched for P or R telemetry. The telemetry is then decoded, stored in the time-based data and made available to the operator for visualization and analysis (see Fig. 6).

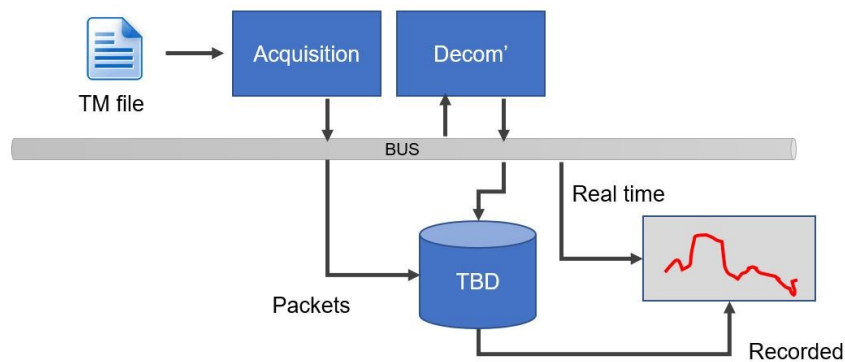

Fig. 6. TM data processing overview

Data packets can be:

- decoded as a whole: in this case, the parameters composing the packets are not decoded and distributed singly, but the packet is decoded as a whole (for instance, most PUS reports).
- decoded as a concatenation of simple parameters. In this case, each parameter composing the packets is decoded singly. These data packets are called "parameters packets" because the parameters may be used independently of each other.

For each parameter contained into the TM packet, the decommutation consists in (see Fig. 7):

- Binary value extraction in order to obtain the extracted raw value
- Application of a coding function in order to obtain the decoded raw value
- Application of an interpretation function in order to obtain the engineering value.

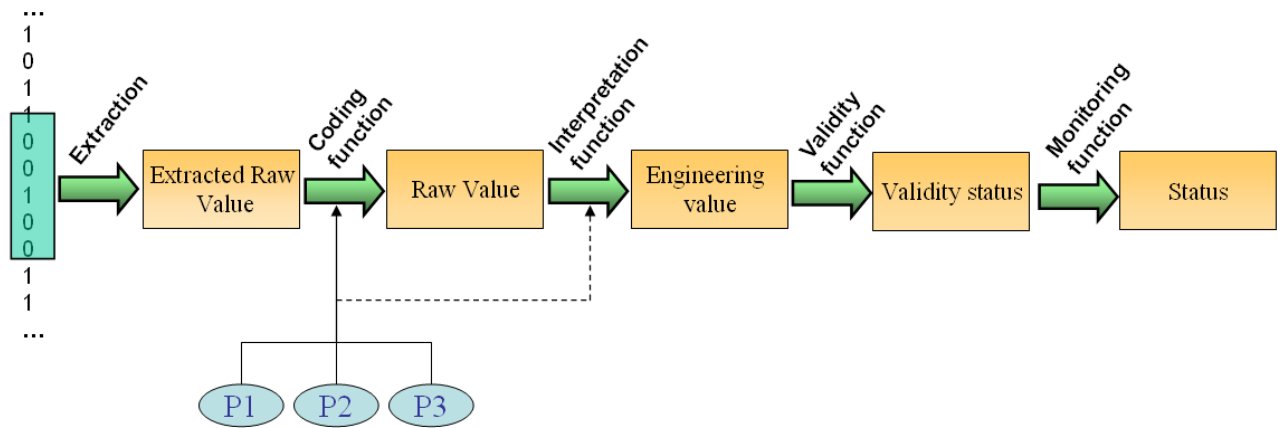

Fig. 7. Decommutation process diagram

Decommutation is robust to TM description incoherence or errors. Such errors do not block the decommutation but generate a report event in order to inform the user of the problem. Therefore, during decommutation, several events can be raised depending on the information found in the telemetry (like PUS information) or depending on thresholds set up for monitoring functions. These events are then distributed to the different components of the CCC in order to, among other things, complete on-board views, update TC history fields and raise operator alerts. Moreover, during the decommutation phase, the detection of gaps in the telemetry data at packet level and frame level automatically raises an event. After decommutation, it is possible to extract telemetry values using recordset functions that allow to pre-set the extraction (filtered extraction). An automatic procedure GOO/GCP is implemented in order to recover HKTM files then perform an acquisition and decommutation telemetry process.

For some PUS services as described in [2], a ground model shall be defined to keep a ground picture of on-board configuration. A CCC from the ISIS-PL has some PUS ground models which display the information supplied by the PUS reports in the satellite telemetry. Depending on the PUS services and subservices selected by the mission, the PUS ground models could be fully or partially complete: the optional fields of PUS reports shall be foreseen in the PUS ground model definition but will be filled in only if they are received in the TM PUS report. The ground models state is published and stored in the time-based data (TBD). It is possible to filter the ground models displayed by each ground model element.

During AIV test phase, several scenarios of decommutation, for LEOP and routine phases, were implemented in order to select the most optimal decommutation strategy in terms of time processing performances and the final chose is described in chapter 6.2.

### 5.2 TC in COF files

In Kinéis system, TCs are encoded (using the SDB) and sent by the CCC to the MCS for encryption and sending to the satellites via the ground stations: there is no link between CCC and the ground stations. The TC flow is mostly based on the Control Operation File (COF) generation and processing. This new interface, containing the encoded telecommand, is sent to the MCS and therefore, no direct connection/flow is established between the CCC and the ground stations.

The COF is a new, not ISIS-standard, interface used in Kinéis mission for sending telecommand to the satellites. The COF file contains the TC for monitoring and control needs, already encoded at packet level by the CCC, that the MCS has to send to the satellites. Most of the time, this interface is generated without knowing the satellite pass that will be used to upload the telecommand. By doing so, the MCS can directly optimizes the TC plan upload. This interface contains several information about the TC to be sent (thematic, priority...), in order to enable the MCS a correct evaluation of the TC plan for the satellite. In order to generate the COF file, the operator needs to prepare the FCP containing the TC information for encoding. The operator shall prepare these FCPs per thematic and generate consequently a COF per thematic (AOCS, EPS, etc.). The encoding of the TC is automatically provided in the COF generation script. Following the COF generation, a COF processing will enable to automatically send the file to the MCS (drop of the file in the exchange server) and create the TC history data necessary for TChistory HMI visualization and PUS model update.

The CCC can also request a COF cancellation through the COF-CANCEL interface to the MCS. This request has to be received by MCS before a configurable delay (MCS\_COF\_TREATMENT\_DELAY) preceding the earliest EARLIEST\_DATE of the N COFs to be inserted in the COF-CANCEL interface. This delay will be defined in the system database. Thus at GCS level, if the time of generation of the COF-CANCEL is too short to respect this deadline, the operator will be notified with an error at the moment of the COF-CANCEL processing.

The MCS can refuse to take the COF-CANCEL request (for all or part of the COFs list) into account, by responding to the CCC with the COF-CANCEL-REJECT file within the two minutes following the cancel request reception. In this case, the reception of the COF-CANCEL-REJECT will automatically raise an alert to be acknowledged by the operator. The operator may, if necessary, re-evaluated the next COF files (operational concepts).

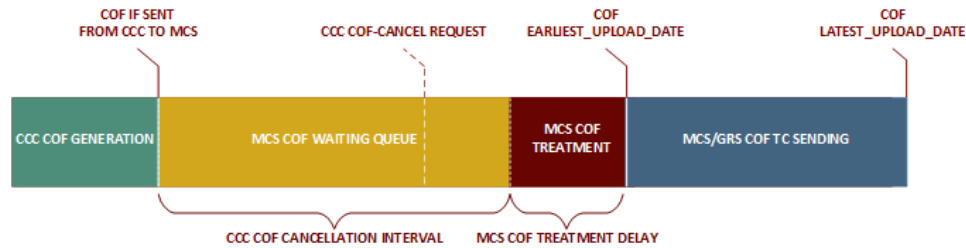

Fig. 8. COF sequence

COFs and their sequences (see Fig. 8) can be generated either manually or, above all, automatically by using pre-validated FCPs.

### 5.3 TChistory, OPS-ACK and COF analyse

The command control centre shall be able to verify the correct sending on ground (MCS to stations), the COP1 acknowledgment and on-board execution of the TC sent to the satellites.

As Kinéis CCC has no active link with the ground stations, unlike MCS, no COP1 mechanism is provided by the CCC. However, the CCC will receive the information about TC sending acknowledgement (ground and COP1 acknowledgement) in the OPS-ACK file sent by the MCS. On-board acknowledgement of the commands (PUS acknowledgements) will be retrieved from the decoded telemetry. These acknowledgements will create a user event (status of acknowledgement). This information will enable to rebuilt the TC history acknowledgements (normally the TC history information are recovered directly from the real time TC flow, and only the PUS acknowledgment are recovered afterwards, after TM decommutation).

The NOK (Not Ok) acknowledgements will automatically trigger an operator alert, with all the information about the NOK reason (COP1 NOK, timeout due to LATEST\_UPLOAD\_DATE, etc.), that will require a manual acknowledgment in order to ensure that the alert has been treated by an operator. Following a NOK acknowledgement, the CCC automatically or manually with operators (depending on the matter) may plan again some of the TC that were not sent or re-evaluate the TC. An overview of the TC history management principles is given in Fig. 9:

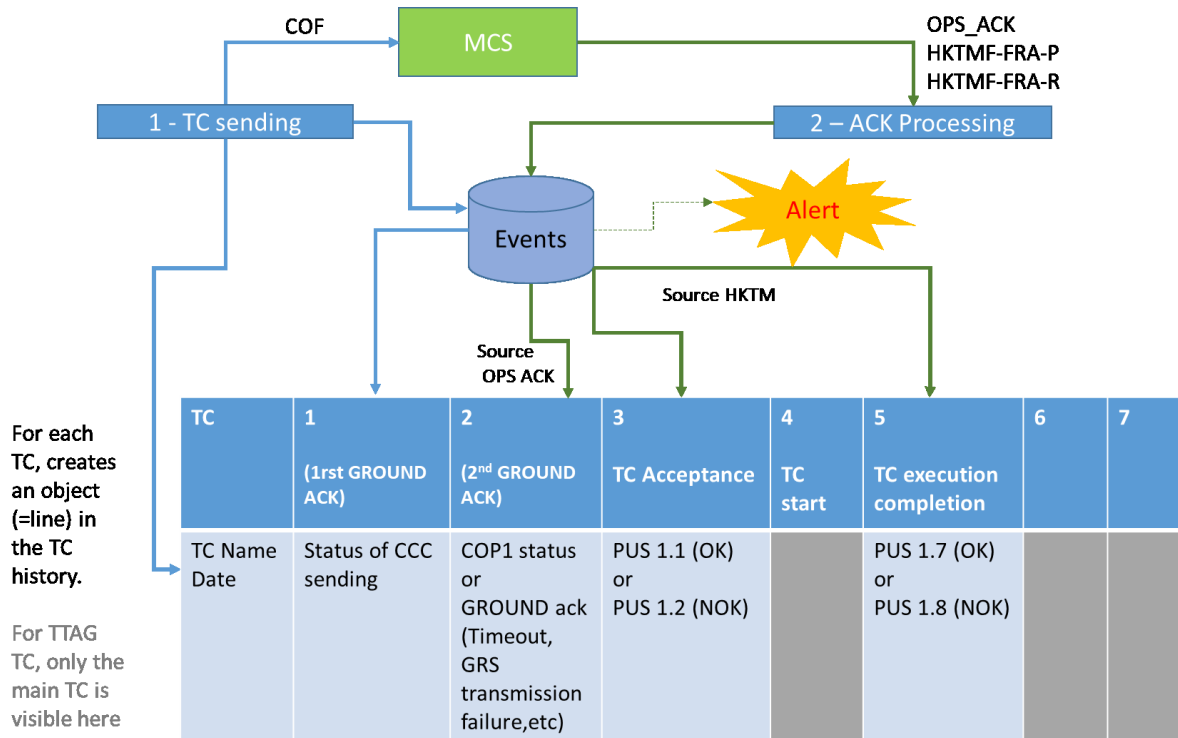

Fig. 9. TC history

According to their status, colours are displayed for each acknowledgement, but also for the TC itself as shown in the next sheets. If an alert is raised, the operator can retrieve information about the reason of the alert via the event manager HMI

However, the TC\_history doesn't clearly reflect the whole process the COF goes through and there are too many TC to follow with no link to the COF sent. To follow the current operations for all the satellites in a COF point of view, a synthetic view of the COF history has been developed. An example of the tool "COF analyse" is given in Fig. 10. It is a dynamic view refresh automatically when a new COF is generated or when an acknowledged arrives and the operator can then focus on a satellite by using filters or on a particular TC by clicking on various links to access COF information.

Index generation date	Number of COF	Oldest COF	Last COF
2025-04-07 07:05:44	2451	2025-01-15T14:36:09 KINAA COFID 1	2025-04-07T06:17:12 KIN4D COFID 251

SAT	ID	Description	Files	Status	Priority	Production date	Earliest upload date	Last upload date	Max cancel date	Nb TC	Nb IMB	Nb TTG	Seq range	TTGSeq range	TTG First date	TTG Last date
KIN4D	251	tc_ping	HTML/XML	SENT	HIGH	2025-04-07T06:17:12	2025-04-07T06:17:09	2025-04-07T13:00:00	2025-04-07T06:15:00	1	1	0	835-835	-	-	-
KINAA	219	tc_ping	HTML/XML	SENT	HIGH	2025-04-07T06:17:11	2025-04-07T06:17:08	2025-04-07T13:00:00	2025-04-07T06:15:00	1	1	0	4654-4654	-	-	-
KIN4C	220	tc_ping	HTML/XML	SENT	HIGH	2025-04-07T06:17:11	2025-04-07T06:17:08	2025-04-07T13:00:00	2025-04-07T06:15:00	1	1	0	6412-6412	-	-	-
KIN4E	219	tc_ping	HTML/XML	ACK_OK	HIGH	2025-04-07T06:17:11	2025-04-07T06:17:08	2025-04-07T13:00:00	2025-04-07T06:15:00	1	1	0	6795-6795	-	-	-
KIN4A	254	tc_ping	HTML/XML	SENT	HIGH	2025-04-07T06:17:10	2025-04-07T06:17:07	2025-04-07T13:00:00	2025-04-07T06:15:00	1	1	0	6490-6490	-	-	-
KIN4A	610	onboard_redatation	HTML/XML	ACK_OK	HIGH	2025-04-07T01:03:37	2025-04-07T01:03:35	2025-04-07T02:04:44	2025-04-07T01:01:35	3	2	1	5447-5449	9326-9328	2025-04-07T02:06:44	2025-04-07T02:06:44
KIN4D	250	onboard_redatation	HTML/XML	ACK_OK	HIGH	2025-04-07T00:47:35	2025-04-07T00:47:33	2025-04-07T01:58:58	2025-04-07T00:45:33	3	2	1	832-834	15851-15851	2025-04-07T01:52:58	2025-04-07T01:52:58
KIN4C	219	onboard_redatation	HTML/XML	ACK_OK	HIGH	2025-04-07T00:47:29	2025-04-07T00:47:27	2025-04-07T02:23:19	2025-04-07T00:45:27	3	2	1	6409-6411	14816-14816	2025-04-07T02:25:19	2025-04-07T02:25:19
KIN4A	218	onboard_redatation	HTML/XML	ACK_OK	HIGH	2025-04-07T00:47:27	2025-04-07T00:47:25	2025-04-07T02:36:00	2025-04-07T00:45:25	3	2	1	4651-4653	14214-14214	2025-04-07T02:38:00	2025-04-07T02:38:00
KIN3B	982	onboard_redatation	HTML/XML	ACK_OK	HIGH	2025-04-07T00:33:15	2025-04-07T00:33:14	2025-04-07T01:33:03	2025-04-07T00:31:14	3	2	1	3716-3718	13928-13928	2025-04-07T01:35:01	2025-04-07T01:35:01
KIN2B	481	onboard_redatation	HTML/XML	ACK_OK	HIGH	2025-04-07T00:18:12	2025-04-07T00:18:10	2025-04-07T01:24:13	2025-04-07T00:18:10	3	2	1	4946-4948	9852-9852	2025-04-07T01:26:13	2025-04-07T01:26:13
KIN2C	428	onboard_redatation	HTML/XML	ACK_OK	HIGH	2025-04-07T00:18:07	2025-04-07T00:18:05	2025-04-07T01:48:29	2025-04-07T00:18:05	3	2	1	1336-1332	15595-15595	2025-04-07T01:50:29	2025-04-07T01:50:29
KIN2D	399	onboard_redatation	HTML/XML	ACK_OK	HIGH	2025-04-07T00:18:05	2025-04-07T00:18:03	2025-04-07T01:38:15	2025-04-07T00:16:03	3	2	1	2707-2709	8323-8323	2025-04-07T01:40:15	2025-04-07T01:40:15
KIN4D	249	tc_ping	HTML/XML	ACK_OK	HIGH	2025-04-07T00:17:12	2025-04-07T00:17:09	2025-04-07T07:00:00	2025-04-07T00:15:00	1	1	0	831-831	-	-	-
KIN4E	218	tc_ping	HTML/XML	ACK_OK	HIGH	2025-04-07T00:17:12	2025-04-07T00:17:09	2025-04-07T07:00:00	2025-04-07T00:15:00	1	1	0	6781-6784	-	-	-
KIN4C	218	tc_ping	HTML/XML	ACK_OK	HIGH	2025-04-07T00:17:12	2025-04-07T00:17:09	2025-04-07T07:00:00	2025-04-07T00:15:00	1	1	0	6408-6408	-	-	-
KIN4A	217	tc_ping	HTML/XML	ACK_OK	HIGH	2025-04-07T00:17:10	2025-04-07T00:17:08	2025-04-07T07:00:00	2025-04-07T00:15:00	1	1	0	4650-4650	-	-	-
KIN4B	203	tc_ping	HTML/XML	ACK_OK	HIGH	2025-04-07T00:17:10	2025-04-07T00:17:08	2025-04-07T07:00:00	2025-04-07T00:15:00	1	1	0	6491-6491	-	-	-
KIN4D	248	tc_ping	HTML/XML	ACK_OK	HIGH	2025-04-06T18:17:12	2025-04-06T18:17:09	2025-04-07T01:00:00	2025-04-06T18:15:00	1	1	0	830-830	-	-	-
KIN4A	216	tc_ping	HTML/XML	ACK_OK	HIGH	2025-04-06T18:17:12	2025-04-06T18:17:09	2025-04-07T01:00:00	2025-04-06T18:15:00	1	1	0	4649-4649	-	-	-
KIN4E	217	tc_ping	HTML/XML	ACK_OK	HIGH	2025-04-06T18:17:11	2025-04-06T18:17:07	2025-04-07T01:00:00	2025-04-06T18:15:07	1	1	0	6783-6783	-	-	-
KIN4E	262	tc_ping	HTML/XML	ACK_OK	HIGH	2025-04-06T18:17:11	2025-04-06T18:17:08	2025-04-07T01:00:00	2025-04-06T18:15:08	1	1	0	6496-6496	-	-	-
KIN4C	217	tc_ping	HTML/XML	ACK_OK	HIGH	2025-04-06T18:17:11	2025-04-06T18:17:09	2025-04-07T01:00:00	2025-04-06T18:15:09	1	1	0	6497-6497	-	-	-
KIN2C	735	onboard_redatation	HTML/XML	ACK_OK	HIGH	2025-04-06T13:03:08	2025-04-06T13:03:06	2025-04-06T14:21:40	2025-04-06T13:01:06	3	2	1	8954-8956	8757-8757	2025-04-06T14:23:40	2025-04-06T14:23:40
KIN2B	692	onboard_redatation	HTML/XML	ACK_OK	HIGH	2025-04-06T13:03:06	2025-04-06T13:03:03	2025-04-06T14:03:37	2025-04-06T13:01:05	3	2	1	7673-7675	10849-10849	2025-04-06T14:05:37	2025-04-06T14:05:37
KIN4B	261	onboard_redatation	HTML/XML	ACK_OK	HIGH	2025-04-06T12:47:34	2025-04-06T12:47:32	2025-04-06T13:55:59	2025-04-06T12:45:32	3	2	1	6487-6489	13084-13084	2025-04-06T13:57:59	2025-04-06T13:57:59
KIN4C	210	onboard_redatation	HTML/XML	ACK_OK	HIGH	2025-04-06T12:47:31	2025-04-06T12:47:29	2025-04-06T14:11:26	2025-04-06T12:45:29	3	2	1	6484-6486	14815-14815	2025-04-06T14:13:26	2025-04-06T14:13:26

Fig. 10. COF analyse

### 5.4 FCP validation with TM flow and a simulator

Only in the frame of FCP validation tests campaigns, the CCC can easily be used in direct connection with the station simulator, receive telemetry and send commands. During CCC “standalone” tests, mostly during FCPs validation campaigns, the MCS is replaced by the TOMS simulator. This process guarantees efficiency and progress of integration and qualification phases, regardless of MCS development progress. The GCS uses another assembly in a specific line called “cc” line when it is connected to the TOMS via a GCS gateway. A gateway can be connected to one satellite only, and so does the GCS however but several gateways can be instantiated (each satellite is configured with its sat identification in the TOMS Manager) and when the connected satellite should change, a simple configuration modification in the port of the gateway allows to connect the GCS to another gateway and hence another satellite. In this configuration:

- Telemetry is received in real-time (instead of files in near real time): a different process from the nominal one will need to be put in place,
- Commands are not encrypted: this has no impact on the validation
- PUS service 1 (TC acknowledgement) is available
- The visibility status is not taken into account for the TM/TC exchange

The TOMS GCS gateway model can also be configured to provide telemetry files.

### 5.5 Additional line for the experts in critical phases

As explained above, a dedicated line of the CCC, called “Expert”, is available during LEOP and others critical phases such as In Orbit Validation (IOV). This line provides access to:

- Telemetry data (raw and decoded)
- COF or other interfaces files stored in particular folders, after a linux transfer from the Production line
- the visualization tool (VIMA): views (mimics, curves) identical to the ones available on the Production line (the views will be centralized in a git repository)
- configurations files (centralized in a git repository)
- published events (i.e. user events for TC acknowledgment or stations events)
- several HMI and tools as available in the Production line

In order to provide the MCR with TM data and events in real time a set of filter/relay daemons are started on the production line and on the Expert line.

### 5.6 TM/TC flows

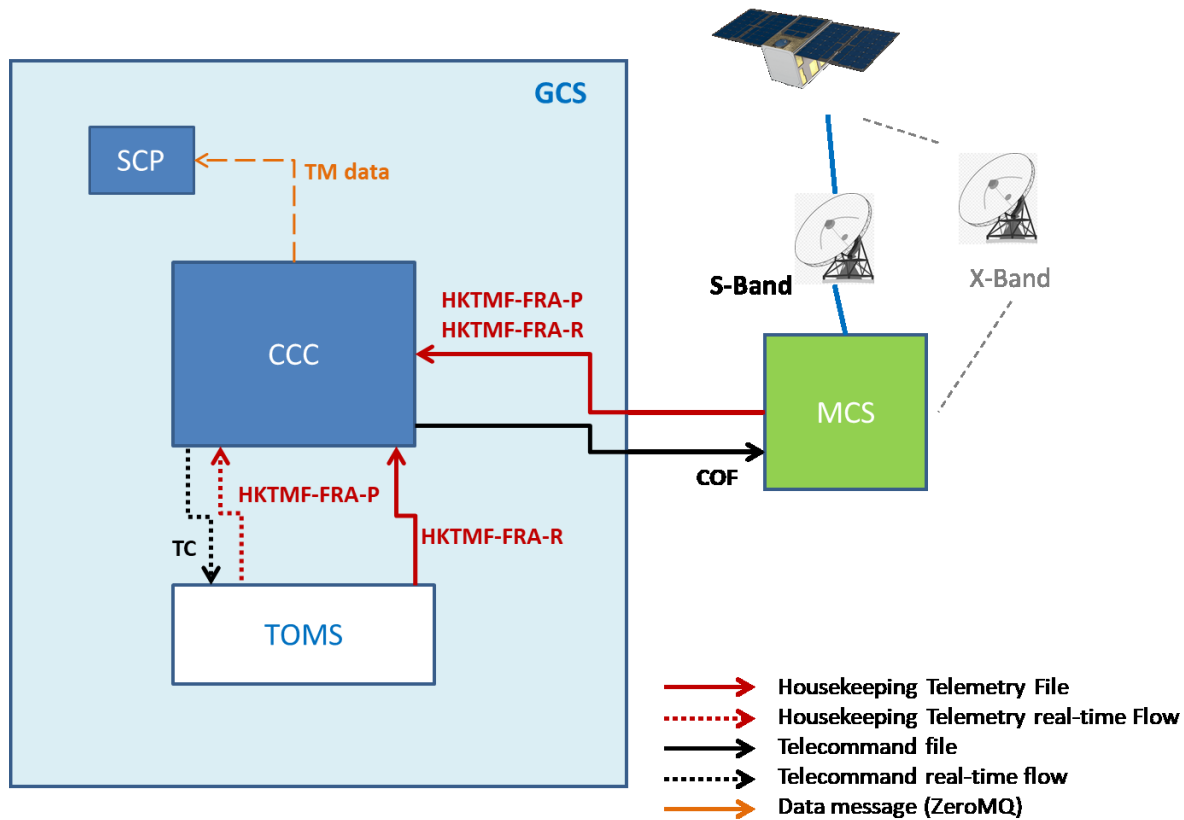

Fig. 11. TM/TC flows

As a summary (see Fig. 11), implementation of Kinéis specificities regarding TM reception and TC sending, is about

- When MCS is present, managing files for near real time TM and TC, instead of real-time flows.
- Without MCS, using the TOMS GCS gateway and its TCP/IP protocol for communications (instead of the SLE gateway protocol commonly used with other CNES simulators) and receiving real-time HKTMF-P in a process that will not be used for Kinéis real operations.

## 6. Automation

### 6.1 The orchestrator (SOO) and the functional chains

In the ISIS product line, the orchestrator is supported by the component called “automation” and the execution of sequences of operations commanding by operational rules and that can be followed in an HMI called SOO and planned by using a CNES tools called APERO. More information about “automation” can be found in [4].

For the Kinéis mission, we are using a single orchestrator to manage all the constellation's activities, respecting the CONOPS specified by Kinéis system team and described in [6]. The rules developed to plan all the operations are complex and defined for all satellites, for a particular satellite or for a plane. In particular, these rules make it possible to manage a 28 days station-keeping manoeuvres cycle as defined by routine CONOPS in [7]. SOO allows sequences of operations to be performed on several functional chains in parallel but we have grouped activities by orbital planes as far as possible to reduce the number of chains. Indeed, a large number of functional chains implies difficulties in terms of readability. A trade-off had to be made to rationalize the number of chains, which had to remain under one person's control, while allowing many operations to be executed in parallel. However, it was necessary to keep one chain per satellite, so as to be able to maintain the operability of a satellite at any given moment, without being limited by the processing of another one. There are 55 chains to operate the Kinéis constellation.

To be efficient in the configuration of the CCC and in its validation, automation and abstraction impose themselves promptly to avoid loss of time. An intermediate layer was introduced especially for Kinéis mission in PULP concepts: the “plan” (constituted of 5 satellites for this constellation). From a ground point of view, this intermediate layer is at the center of operational concepts but can brought also a time benefit when the phases (due to time launch) are different between the satellites for instance. To optimize hardware resources, a particular effort has been intellectually realized in the sequencing of operations. Same operations on planes and satellites have a time-offset (quarter of an hour between each planes and two minutes between each satellite, for instance) to not overload the same resources at the same time, but stay time-consistent. Therefore, at the end, the 24 hours’ timeline is almost always occupied with an available ground maintenance window at launch time (see Fig. 12). Operators plan this timeline in “just several clicks” and few minutes thanks to variable and operational rules, which calculate the operations for the overall constellation depending on the weekday, on the cycle, etc.

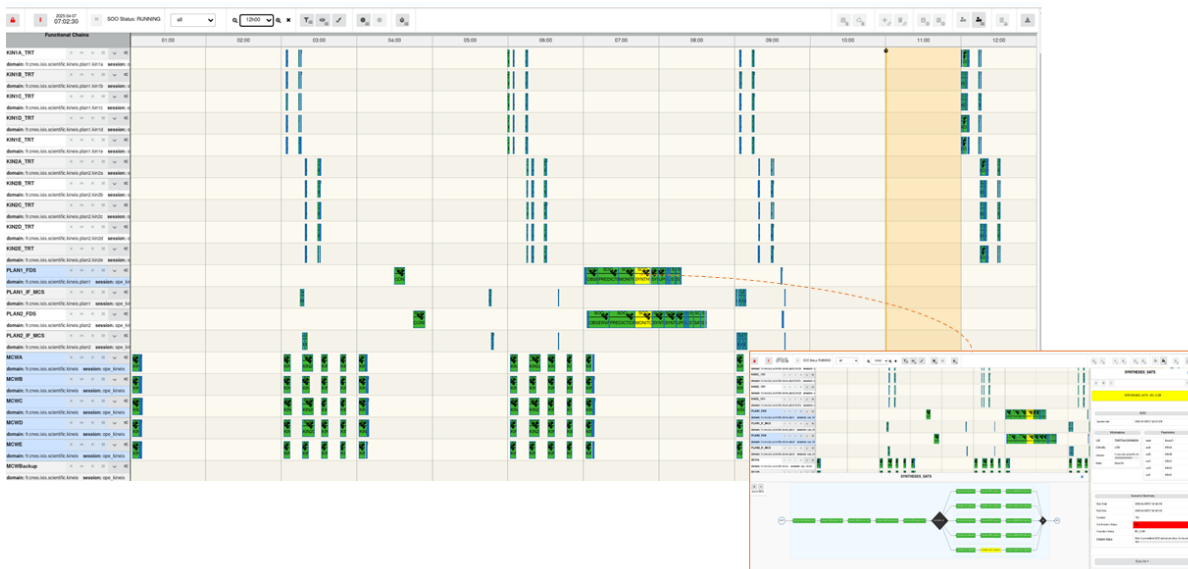

Fig. 12. SOO orchestrator example filtered for two planes and a GOO

In addition of predefined operations, the ISIS Product Line architecture of “reflex rules” allow to trigger special operations on a combination of criterion. This mechanism is the one that trigger the on-call operators at the detection of critical board alarm for example or the safe mode specific activities as explained in the next chapter.

The SOO HMI of ISIS-PL allows displaying all planned operations. SOO is adaptable and Operators can easily add new exceptional activities in the restricted schedule, with a minimum level of coordination with Ground Operator, responsible of the scheduling and its correct execution. To maximize Operators exceptional activities, Ground Control HMI of the PULP community allow scheduling predefined activities in two of mouse clicks (selecting the activity, the satellite for instance). This way of working also reduce Operational risks to launch an operation on the wrong satellite, which can be more frequent with the use of terminal (even if this is still possible and not technically prohibited).

### 6.2 Focus on TM processing and mcworkers

From TM processing point of view, there are 3 phases, it means 3 functional modes:

- In routine phase, the GCS only treats HKTM-R because all information for satellite health checks are available in HKTM-R and because the GCS only need to realize a differed-time monitoring on the 80 passes per day par satellite. TM processing should then occur regularly and we have chosen a reasonable frequency of 3 hours for each satellite of the constellation.
- In LEOP phase, where operations are critical (satellites not yet known) and realize 24/7, the TM from all passes should be quickly processed and analyzed. In this case, HKTM-P files are treated in the middle of the pass and HKTM-P and HKTM-R files are treated post-pass.

- When a safe mode transition is seen, we want to get all the TM available around the transition (3 hours before and 2 hours after) to analyze the problem later during an on-call activity, so 1 hour after the safe transition or during routine activities if it is not critical.

A total of 5 VMs mcworkers (named a to e) are available for M&C tasks in particular HKTМ processing, plus a 6th called backup mcworker (named z) dedicated to support specific activities for any of the 25 satellites. Allocation of a mcworker to a given satellite is not dynamically, but set in advance in the configuration. So by configuration, the 5 satellites of the same planes are dispatched on 5 different mcworkers. The satellites with the same “rank” (e.g. “A”) are assigned to the same mcworker (e.g. mcworkerA). This enables simultaneous TM processing for the satellites of a same orbital plan. One backup mcworker, usable for any of the 25 satellites, supports specific operations including safe mode emergencies. However, if multiple critical situations arise, choice of the mcworker to use remains under operator’s control.

The chart in Fig. 13 shows the main principles of implementation with parallel TM processes running on the 5 mcworkers.

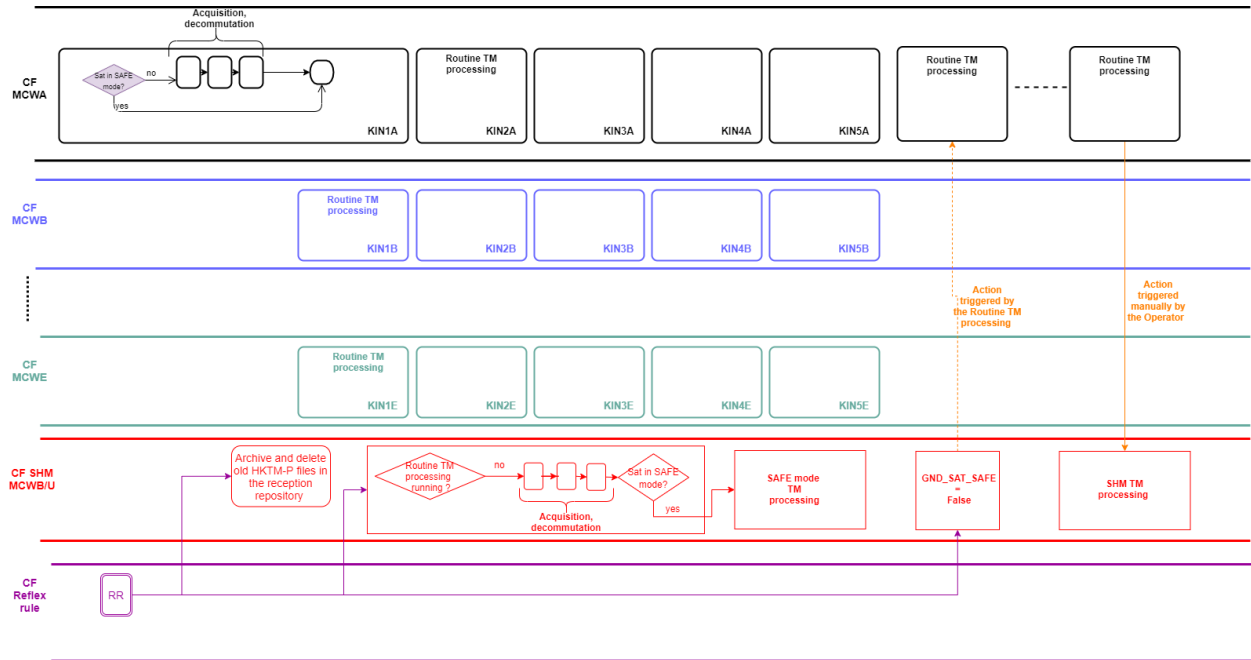

Fig. 13 principles of TM processing implementation in the SOO

Implementation of TM processing activities for all satellites in parallel and according to the operational phase (LEOP, ROUTINE and SAFE mode) is based on the capability to:

- Schedule nominal activities on the 5 mcworkers (A to E) in parallel
- Set up a reflex rule on the 6th mcworker to deal exceptional TM treatments
- Switch activities from nominal to safe mode and vice-versa when needed and automatically

The TM processing procedure start by testing the current satellite mode (GND\_SAT\_SAFE\_MODE=True). The rationale is that TM processing activities schedule on the functional chains remains unchanged even if SAFE mode was raised earlier. So if safe mode is active, routine activities will just be skipped, and the next procedure scheduled for a different satellite on the same chain will be able to start.

SAFE mode is only triggered via a reflex rule on the WARN-SAT file reception (a file produce by a station when it saws a drop in flow rate), it is not triggered using the TM itself. So upon WARN-SAT reception, exceptional TM treatments are done on the specific mcworkerz. Thus, TM processing activities on SAFE mode for more than one satellite will need to be intertwined. A maximum number of satellites in safe mode simultaneously may be required in order not to saturate the backup mcworker. At this point, no more than 2 safe mode situations are expected at the same time.

## 7. Constellation monitoring

VIMA is a visualization GUI. It allows to visualize all the data types present in the CCC (parameters, PUS models, supervision data...) and it offers several view types (text views and labels, plot views, synoptic, HTML...). Real time and archived data are browsed transparently through a timeline cursor. Classical features are available as well (zoom-in, zoom-out, sampling, drag-and-drop from SDB explorer...). More information on visualization concepts in ISIS-LP can be found in [3]. VIMA has been conceived in ISIS PL with a high level of configuration to answer to large range of use cases and missions and allowing Operator to define its supervision board in autonomy. It works either in differed time (for analysis purpose), or in real time with an update at the publication of the data. During LEOP phase, VIMA has allowed to visualize specific parameters in order to monitor correctly this critical phase (see an example in Fig. 14). However, during Routine phase, VIMA current limitation to 6 hours' data due to performance and robustness issues has lower its use. Indeed, Operators prefer to focus on 24 hours of data, which is seeking to be possible in the next versions of VIMA.

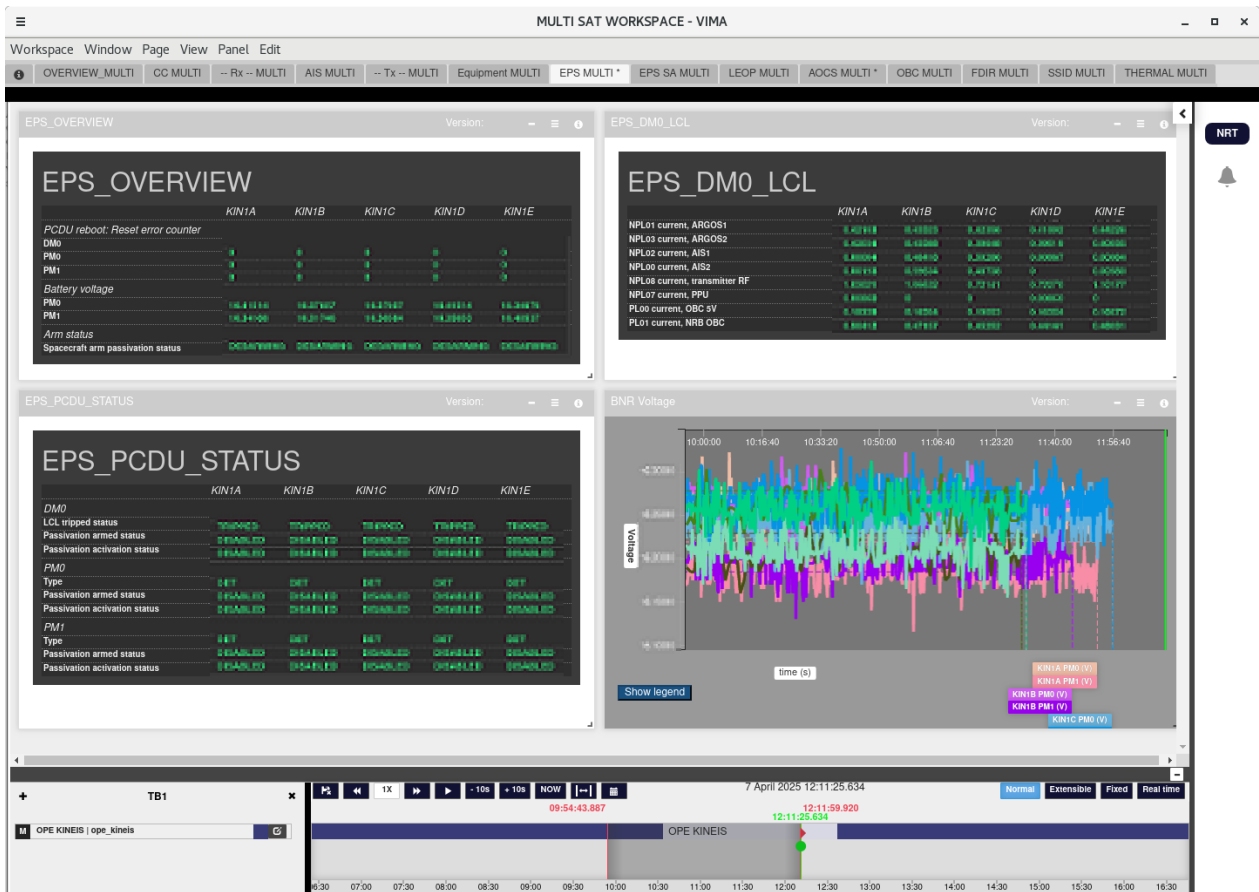

Fig. 14. VIMA view of a plane specific parameters

Board Operators use another tool of the ISIS-PL called Event Manager, with dedicated configuration grouping events on user's criteria. This process allows to have a global supervision of alarms for instance and then to be able to enter into detailed events and to acknowledge the alarms directly in the visualization (see Fig. 15).

Satellite	Application time	Nature	Event class	Type	Criticity	Message	Ack status
1	08.04.2025 - 23:53:48:364	GROUP-Passage	Number of events: 2486	TC_LOS			
2	07.04.2025 - 07:00:55:874	GROUP-FCP_Histo	Number of events: 20245	Procedure_ConfirmationStatus			
3	06.04.2025 - 18:48:11:917	GROUP-Trou_TM	Number of events: 51	POST_TM_HHTMR_hole			
4	07.04.2025 - 00:47:20:121	GROUP-Delta_TB_TS	Number of events: 24	Delta_Times_Threshold			
5	08.04.2025 - 23:54:27:657	GROUP-OEP_FDS	Number of events: 5170	DESCENDING_NODE			
6	04.04.2025 - 18:49:38:000	GROUP-PUS_Activities	Number of events: 305	Pus_Activity			
7	07.04.2025 - 06:20:31:000	GROUP-Alarme	Number of events: 406	PUS_005_MONITORING_ALARM_EVENT			
8	KIN4A 06.04.2025 - 04:00:51:968	Logbook		POST_TM_checkConfTableCrc	INFO	The CRC for NVM1_L_CCSW_CT is different between last checked CRC (0bb0de) and last saved CRC (0a99b2).	None
9	KIN4A 04.04.2025 - 09:59:20:639	Logbook		POST_TM_Alarm_acq_negatif_PUS001	ERROR	On KIN4A between 2025-04-04T06:34:49.148 to 2025-04-04T09:59:11.799, we received 0 TM(1,2), 0 TM(1,4), 0 TM(1,6) et 1 TM(1,8)	Done TC DOF MCS
10	KIN4A 04.04.2025 - 12:59:20:618	Logbook		POST_TM_Alarm_acq_negatif_PUS001	ERROR	On KIN4A between 2025-04-04T09:32:35.134 to 2025-04-04T12:59:11.757, we received 0 TM(1,2), 0 TM(1,4), 0 TM(1,6) et 1 TM(1,8)	Done TC DOF MCS
11	KIN4B 03.04.2025 - 12:51:01:265	Logbook		CallUrgent	INFO	Creation of an urgent alert for operator BORD on satellite KIN4B with messageid : 1001. Comment OPS-ACK KO Coffid 238 ...	Done SEND NO COPI
12	KIN4B 04.04.2025 - 15:49:58:617	Logbook		CallUrgent	INFO	Creation of an urgent alert for operator BORD on satellite KIN4B with messageid : 1001. Comment OPS-ACK KO Coffid 247 ...	Done COF PUS1 OK
13	KIN4B 06.04.2025 - 04:00:45:015	Logbook		POST_TM_checkConfTableCrc	INFO	The CRC for NVM2_L_PROPLUSION_CT is different between last checked CRC (0bc6a) and last saved CRC (0x5c4c).	None
14	KIN4B 06.04.2025 - 04:00:45:018	Logbook		POST_TM_checkConfTableCrc	INFO	The CRC for NVM2_L_CCSW_CT is different between reference CRC (0ba46) and last saved CRC (0d9337).	None
15	KIN4B 06.04.2025 - 04:00:45:020	Logbook		POST_TM_checkConfTableCrc	INFO	The CRC for NVM2_L_CCSW_CT is different between last checked CRC (0x5bc) and last saved CRC (0d9337).	None
16	KIN4C 06.04.2025 - 04:00:57:555	Logbook		POST_TM_checkConfTableCrc	INFO	The CRC for NVM1_L_PROPLUSION_CT is different between reference CRC (0a5280) and last saved CRC (0ba606).	None
17	KIN4C 06.04.2025 - 06:00:57:557	Logbook		POST_TM_checkConfTableCrc	INFO	The CRC for NVM1_L_CCSW_CT is different between last checked CRC (0ba6c8) and last saved CRC (0da910).	None
18	KIN4C 06.04.2025 - 18:59:21:477	Logbook		POST_TM_Alarm_acq_negatif_PUS001	ERROR	On KIN4C between 2025-04-06T15:40:20:983 to 2025-04-06T19:59:13.780, we received 0 TM(1,2), 0 TM(1,4), 0 TM(1,6) et 1 TM(1,8)	Done TC redation b ITG
19	KIN4C 04.04.2025 - 15:49:51:671	Logbook		CallUrgent	INFO	Creation of an urgent alert for operator BORD on satellite KIN4C with messageid : 1001. Comment OPS-ACK KO Coffid 203 ...	Done PUS1 OK
20	KIN4C 06.04.2025 - 15:49:48:005	Logbook		CallUrgent	INFO	Creation of an urgent alert for operator BORD on satellite KIN4C with messageid : 1001. Comment OPS-ACK KO Coffid 216 ...	Done TC resté bloqué
21	KIN4D 04.04.2025 - 06:59:23:083	Logbook		POST_TM_Alarm_acq_negatif_PUS001	ERROR	On KIN4D between 2025-04-04T03:13:53.796 to 2025-04-04T06:59:16.983, we received 1 Comment TM(1,2), 0 TM(1,4), 0 TM(1,6) et 0 TM(1,8)	Done restart lé au hc
22	KIN4D 04.04.2025 - 09:59:21:202	Logbook		POST_TM_Alarm_acq_negatif_PUS001	ERROR	On KIN4D between 2025-04-04T06:24:18.577 to 2025-04-04T09:59:14.150, we received 2 TM(1,2), 0 TM(1,4), 0 TM(1,6) et 0 TM(1,8)	Done restart lé au hc
23	KIN4D 04.04.2025 - 18:59:21:239	Logbook		POST_TM_Alarm_acq_negatif_PUS001	ERROR	On KIN4D between 2025-04-04T12:27:10.140 to 2025-04-04T15:59:14.953, we received 3 TM(1,2), 0 TM(1,4), 0 TM(1,6) et 0 TM(1,8)	Done restart lé au hc
24	KIN4D 04.04.2025 - 06:59:34:761	Logbook		POST_TM_rebootObs	WARNING	There is OBC reboot at 2025-04-04T04:54:23.685	Done restart lé au hc

Fig. 15. SyBordG a customization of Event Manager to supervise a weekend alarms of one plane

FDS operators have also set up HTML summaries to keep track of all their processing operations and can access all details such as specific plots or logs by clicking on links. (See Fig. 16).

[Sommaire](#) > Index du Dimanche 6 Avril 2025 (après-midi)

## FDS



SYNTHESIS MAIN PAGE

### Individual satellites syntheses :

	Plane 1				Plane 2				Plane 3				Plane 4				Plane 5			
	ORB	PROG	MAN	MON	ORB	PROG	MAN	MON	ORB	PROG	MAN	MON	ORB	PROG	MAN	MON	ORB	PROG	MAN	MON
Satellite A																				
Satellite B																				
Satellite C																				
Satellite D																				
Satellite E																				

### Plane syntheses :

	Plane 1	Plane 2	Plane 3	Plane 4	Plane 5
FDS Executions Synthesis					
Global Synthesis					

### Constellation syntheses :

	All Planes
Conjunctions synthesis	

Fig. 16. FDS synthesis

A specific aspect of constellation is the monitoring of the satellites linked with the Human-resources restriction constraints. Visualization's synthesis is, thus, at the center of the constellation concepts. As well as the other ISIS-PL missions, HMI to monitor telemetry by satellite is used for analysis purposes. However, not architecture issues but performances issues in used versions, have been encountered when more than 5 satellites and a large number of information are wanted to be displayed at the same time. This is why, a new HMI V2S (see Fig. 17) has been especially developed, in short notice, in order to have a global view of the 25 satellites on one large screen and to know from one glance the essential, such as for each satellite: the satellite mode, the presence of on-board or ground monitoring alarms, payload modes, etc. This allows rapidly have an idea of the health and configuration of the constellation. This HMI can be reused by future missions with modifications in the configuration file.



Fig. 17. V2S synthetic view of the constellation status

To monitor the status of the entire infrastructure, a Grafana dashboard has been configured thanks to templates of different ISIS missions, supplemented by specific operator alerts in the most critical cases (see Fig. 18):

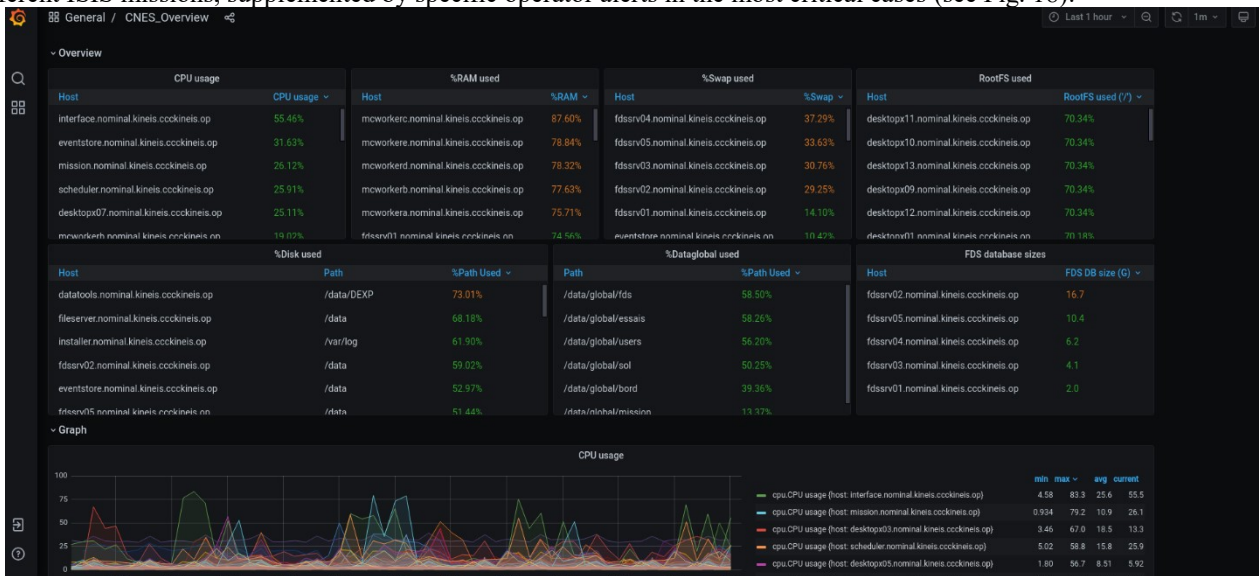

Fig. 18. Infrastructure supervision in Grafana

## 8. Feedbacks and best practices

The CCC Kinéis has now been operating for almost a year without a breakdown and at full capacity for several months. As a result, here are list the key points and best practices met during the development of Kinéis CCC:

- Removal of the real time concept and focus on the deferred time concept,
- Accept a change of operation for a constellation (e.g. delayed TC acknowledges),
- Automate as much as possible to minimize human actions,
- Define operational concepts that can be completely automated,
- The possible performance problems have to be analyzed from the very beginning during AIV tests even if it remains complicated to obtain representative data at the start of a project,
- Important architecture choices at the outset, but leave the door open to possible changes,
- Synthetic HMIs available for easy monitoring of satellites and center status,

- Be flexible to operational changes (thanks to rules/layer for us this was the case),
- Define real needs and priorities with the operators,
- The TM monitoring plots solution must be efficient even over time intervals of the order of a day and solutions for long-term or statistical analysis of telemetry must be available to enable trend monitoring.

## 9. Conclusions

A major challenge was met by CNES, which was able to deliver a CCC for a small constellation rapidly implemented on the basis of all the ISIS-PL and PULP operational concepts even if they were not initially made for more than 3 satellites. The adaptations were efficient and well-used for 25 in-flight satellites. This CCC is flexible and has made it possible to manage all the AIV, LEOP, Routine and SAFE phases of the Kinéis satellites, grouping activities by planes and automating as far as possible all the operational activities from the monitoring or file treatment basic functions to the overall summary supplied to operators.

## References

- [1] J.G. Walker “Satellite Constellations”. In *Journal of the British Interplanetary Society* 37 (Dec. 1984) p 559.
- [2] Space engineering Telemetry and telecommand packet utilization, ECSS-E-ST-70-41C, 15 April 2016 <https://ecss.nl/wp-content/uploads/2016/06/ECSS-E-ST-70-41C15April2016.pdf>
- [3] Toussaint François and Clémence Samitier, New operability concepts within ISIS mission operations ground segment, AIAA 2018-2548, 2018 SpaceOps Conference, Marseille, France, May 2018.
- [4] Clément Hubin-Andrieu, CNES 'Automation', a generic solution to face today's necessities, IAC-24,B6,1,3,x82792, International Astronautical Congress 2024, Milan, Italy, 14-18 October 2024
- [5] Paul Gélie, Helene Pasquier and Yves Labrune, CNES Mission Operations Systems roadmap : towards rationalisation and efficiency with ISIS, AIAA 2018-2628, 2018 SpaceOps Conference, May 2018
- [6] Anissa Bahri, Franck Darnon, Nicolas Soulard, Benjamin Morel, Damien Servant, Innovative Operational Concepts & Organization to meet the operation challenges of the Kinéis constellation, SpaceOps-2025, ID # 277 (*upcoming publication*)
- [7] Guillaume Azema, Jules David, Jesus Esteban-Dones, Mission Analysis and Flight Dynamics Operations for Kinéis mission, SpaceOps-2025, ID # 484 (*upcoming publication*)